

SECTION A

QUESTION 1: ONE-WORD ITEMS

Give ONE word/term for each of the following descriptions. Write only the word/term next to the question number (1.1 – 1.5) in the ANSWER BOOK.

- 1.1 It is a conservative force. (1)
- 1.2 The minimum amount of energy required to remove an electron from a metal surface. (1)
- 1.3 The relationship between impulse and change of momentum. (1)
- 1.4 The term used to describe light of a single frequency. (1)
- 1.5 The type of collision in which kinetic energy is conserved. (1)

[5]

QUESTION 2: MULTIPLE-CHOICE QUESTIONS

Four options are provided as possible answers to the following questions. Each question has only ONE correct answer. Write only the letter (A – D) next to the question number (2.1 – 2.10) in the ANSWER BOOK.

- 2.1 A ball of mass m strikes a wall perpendicularly at a speed v . Immediately after the collision the ball moves in the opposite direction at the same speed v , as shown in the diagram below.

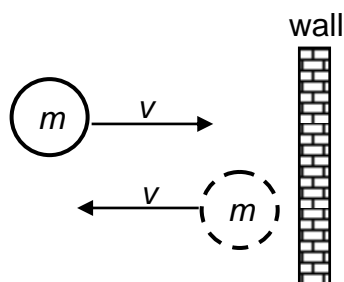

Which ONE of the following represents the magnitude of the change in momentum of the ball?

- A 0 B mv C $2mv$ D $3mv$

(2)

2.2 An object projected vertically upwards reaches its maximum height and returns to its original point of projection. Ignoring the effects of friction, the direction of the acceleration of the object during its motion is ...

- A always vertically downwards.
- B first vertically upwards and then vertically downwards.
- C first vertically downwards and then vertically upwards.
- D always vertically upwards.

(2)

2.3 A stone is thrown vertically upwards and returns to the thrower's hand after a while. Which one of the following velocity – time graphs best represents the motion of the stone ?

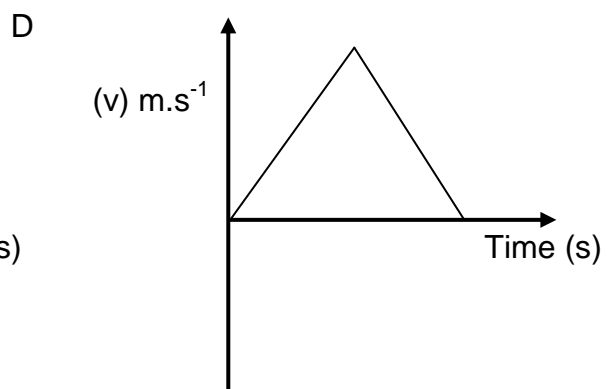
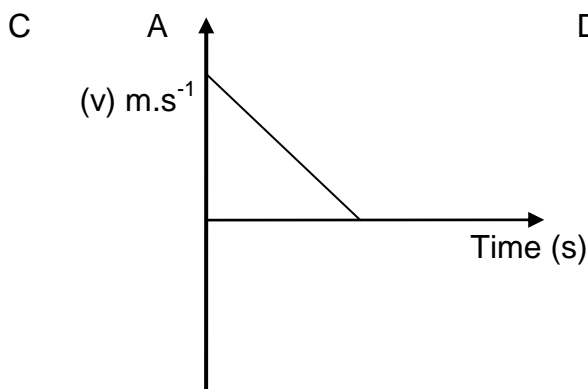
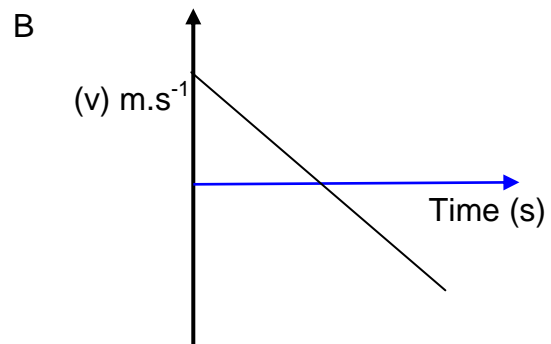
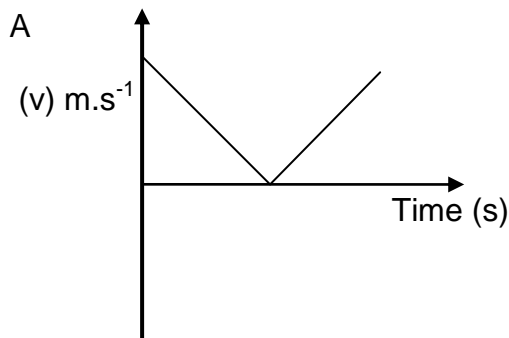

(2)

2.4 Of all the groups in the electromagnetic spectrum, gamma rays have the greatest penetrating ability because they have:

- A The longest wavelength
- B The fastest speed
- C The highest frequency
- D Particle nature

(2)

2.5 A person dives from a high platform into a pool. At which ONE of the positions A, B, C or D will the magnitude of his momentum be a maximum?

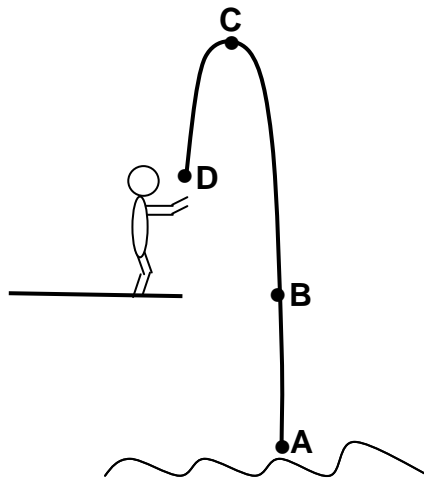

- A Position A
- B Position B
- C Position C
- D Position D

(2)

2.6 A force, F , acts on a body of mass, m , and produces an acceleration, a . If you double the mass of the body while the force remains constant, the acceleration will ...

- A increase to $4a$
- B decrease to $\frac{1}{4}a$
- C decrease to $\frac{1}{2}a$
- D increase to $2a$

(2)

2.7 In the following circuit diagram, the internal resistance of the battery is so small that you can ignore it.

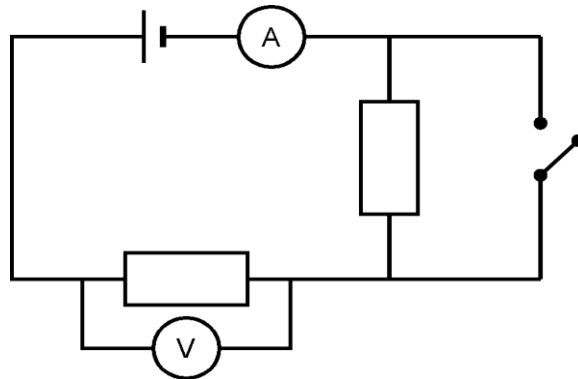

How do the readings on the ammeter and voltmeter change if you close the switch?

| | Ammeter reading | Voltmeter reading |
|---|-----------------|-------------------|
| A | decreases | decreases |
| B | increases | increases |
| C | decreases | increases |
| D | increases | decreases |

(2)

2.8 Consider the statements below :

- i Work is done on an object when a force displaces the object in the direction of the force.
- ii Mechanical energy of a system is conserved when an external force does no work on the system.
- iii The work done on an object by a net force is equal to the kinetic energy of the object.

Which of the following statements is/are TRUE ?

- A Only i
- B i and ii only
- C ii and iii only
- D i , ii and iii

(2)

2.9 The siren of a police car , travelling at a speed v , emits sound waves of frequency f

Which ONE of the following best describes the frequency that will be observed by a passenger in a car right behind the police car at a speed v ?

- A Zero
- B Smaller than f
- C Equal to f
- D Greater than f

(2)

2.10 When a clean metal plate is irradiated with light of sufficient energy, photoelectrons are emitted. The INTENSITY of the light is now increased. This change will ...

- A increase the number of photoelectrons emitted per second.
- B decrease the number of photoelectrons emitted per second.
- C increase the kinetic energy of the emitted photoelectrons.
- D decrease the kinetic energy of the emitted photoelectrons.

(2)

[20]

SECTION B

INSTRUCTIONS AND INFORMATION

1. Start EACH question on a new page.
2. All sketches and general layout of your work must be neat.
3. Show the formulae and substitutions in ALL calculations.
4. Round off your numerical answers to TWO decimal places.

QUESTION 3

The velocity-time graph shown below represents the motion of two objects, **P** and **Q**, which were released from the same height, simultaneously. Object **P** is released from REST. (Ignore the effects of friction)

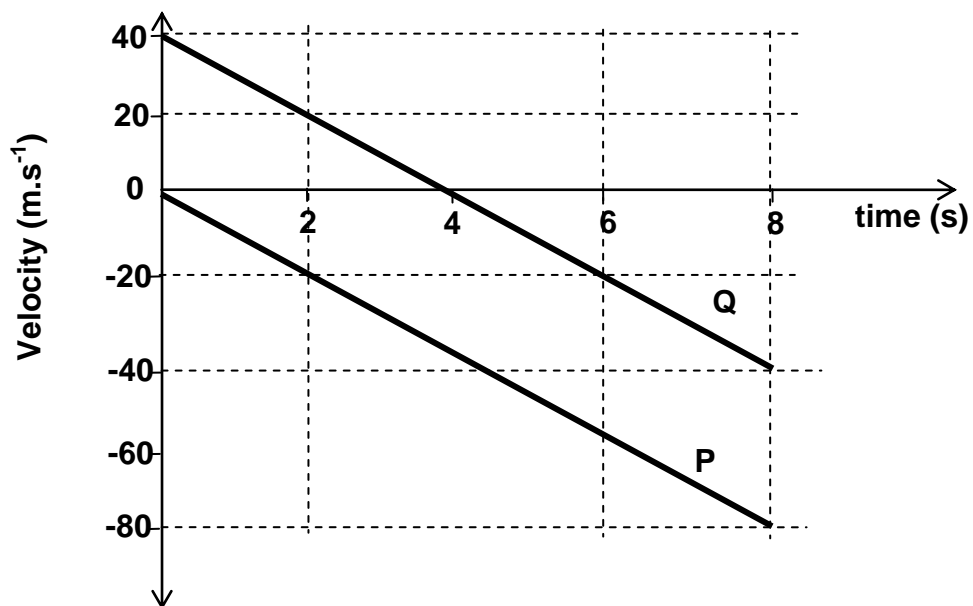

- 3.1 Give a reason why object **P** moves with constant acceleration by referring to the graph. (No calculations are required) (2)
- 3.2 Use the graph to determine the time that object **Q** takes to reach its maximum height. (A calculation is not required.) (1)
- 3.3 Calculate the maximum height that object **Q** reaches above the ground. (4)
- 3.4 At what time/times is the speed of object **Q** 20 m.s⁻¹? (2)

- 3.5 Object **P** strikes the ground after falling for 8 s. USE EQUATIONS OF MOTION to calculate the height from which the objects were released. (4)
- 3.6 What is the velocity of object **Q** relative to object **P** at $t = 2$ s? (3)
- 3.7 Calculate, WITHOUT USING EQUATIONS OF MOTION. The distance between objects **P** and **Q** at $t = 2$ s. (5)
- 3.8 Draw a position-time graph to show the whole motion of object **P**. Take the height from which both objects were released as ZERO OF POSITION. (3)

[24]

QUESTION 4

- 4.1 State the law of the conservation of linear momentum. (3)
- 4.2 In a crash test , a car of mass $1,2 \times 10^3$ kg collides with a wall and rebounds in a direction a certain direction .The initial and final velocities of the car are $12\text{m}\cdot\text{s}^{-1}$ to the left and $2\text{m}\cdot\text{s}^{-1}$ to the right respectively. The collision lasts for 0,1s.
- Calculate the :
- 4.2.1 change in momentum of the car during the accident. (4)
- 4.2.2 the impulse of the car. (2)
- 4.2.3 the average force exerted on the car (3)
- 4.3 How will the magnitude of the force exerted on the car be affected if the time interval of the collision remains 0,1s , but the car does not bounce off the wall ? Write down only INCREASES , DECREASES or REMAINS THE SAME. Explain your answer (3)

[15]

QUESTION 5

The siren of a police car chasing a burglar is switched on after it passes a learner standing on a road. The police car was travelling at $306 \text{ km}\cdot\text{h}^{-1}$ and the frequency of the sound waves emitted by its siren was 2500 Hz. The speed of sound in air is $340 \text{ m}\cdot\text{s}^{-1}$.

- 5.1 Name the phenomenon responsible for the observed change in frequency. (1)

- 5.2 Convert $306 \text{ km}\cdot\text{h}^{-1}$ to $\text{m}\cdot\text{s}^{-1}$. (1)
- 5.3 The learner hears the siren of the police car at a lower frequency. Use an appropriate sketch in terms of sound waves to explain this. (3)
- 5.4 Calculate the frequency of the sound waves of the siren that was heard by the learner (5)
- [10]

QUESTION 6

An object of mass 5 kg is travelling at $8 \text{ m}\cdot\text{s}^{-1}$ when it passes position **A**. It then reaches position **B** along a horizontal path, after losing 70 J of energy due to friction between position **A** and **B**. It then continues its motion down an incline to reach position **C** with a velocity of $12 \text{ m}\cdot\text{s}^{-1}$. The vertical height of position **B** above position **C** is 10 m .

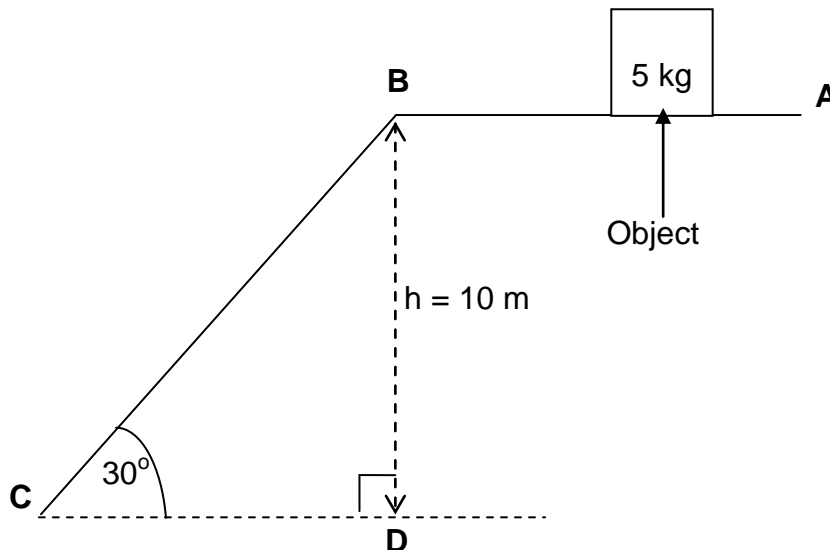

- 6.1 Draw a free body diagram to show all the forces that are acting on the object as it travels between position **A** and **B**. (3)
- 6.2 State the Work-Energy Theorem in words. (2)
- 6.3 Use the Work-Energy Theorem to prove that the speed of the object at position **B** is $6 \text{ m}\cdot\text{s}^{-1}$. (4)
- 6.4 Draw a free body diagram to show all the forces that are acting on the object as it travels between position **B** and **C**. (3)
- 6.5 Determine the length of **BC**. (2)
- 6.6 Write down an expression to determine the relationship between the ΔE_K , $W_{//}$ and W_f . (1)

6.7 Use the expression in 6.6 determine the magnitude and direction of frictional force that acted on the object between position **B** and **C**. (6)

6.8 If the object fell vertically in the absence of friction from position **B** to position **D**, would its velocity at **D** be GREATER THAN, SMALLER THAN or EQUAL TO its velocity at **C**? (1)

[22]

QUESTION 7

A learner uses a single slit to determine the wavelength of a red laser light. He sets up the slit and screen as shown below and shines the laser through the single slit of width $7,25 \times 10^{-6}m$. The distance between the screen and the slit is $0,4m$.

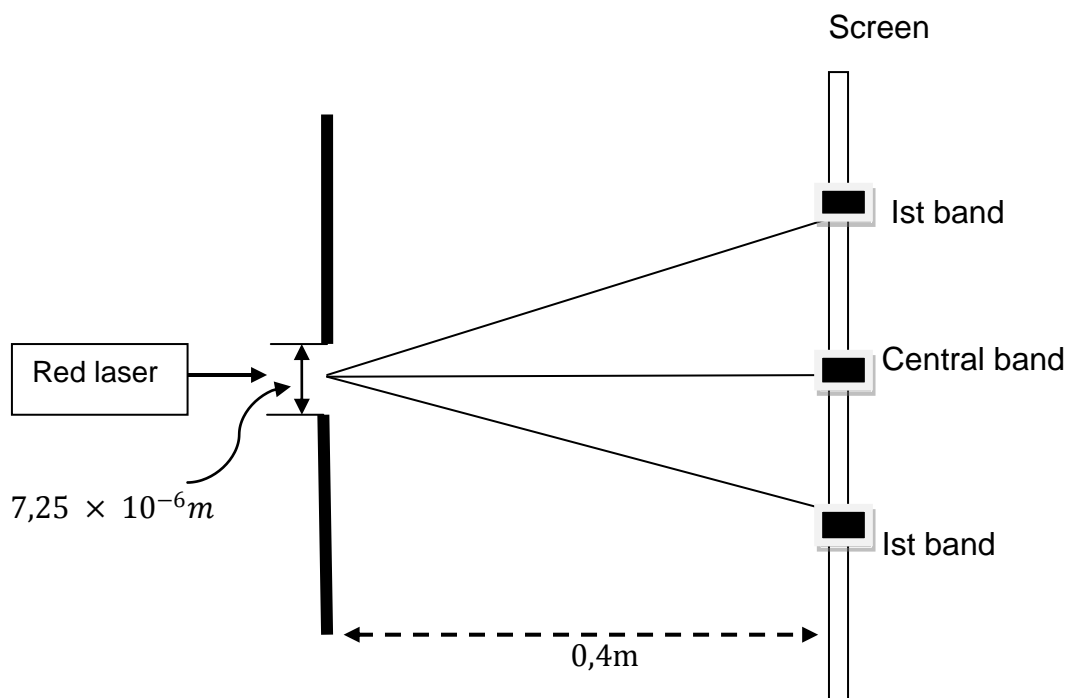

7.1 Define Huygen's Principle. (3)

7.2 Name the type of pattern observed on the screen. (1)

7.3 Name the type of interference that takes place when the dark bands forms on the screen. Write down the name of the dark band. (2)

7.4 Draw a neat labelled cross section of the pattern formed on the screen. (3)

7.5 State ONE safety precaution that the learner must take when using the above apparatus. (1)

- 7.6 The learner measures the distance between the midpoint of the central bright band and the first dark band as $3,5\text{cm}$.

Calculate the wavelength of the red laser light .

(6)

- 7.7 The learner wants to decrease the distance between the midpoint of the central bright band and the first dark band.

What TWO changes can the learner make to the above arrangement to achieve this.

(2)

[18]

QUESTION 8

Sunlight is a major source of ultraviolet light.

- 8.1 Overexposure to ultraviolet light could have harmful effects on humans. State ONE of these harmful effects on humans.

(1)

- 8.2 Medical practitioners expose surgery equipment to ultraviolet light. Give a reason for doing this.

(1)

A certain metal has a work function of $3,84 \times 10^{-19} \text{ J}$. The surface of the metal is irradiated with ultraviolet light of wavelength 200 nm causing photoelectrons to be emitted.

- 8.3 Calculate the energy of a photon of ultraviolet light.

(5)

- 8.4 Calculate the maximum velocity of the emitted photoelectrons.

(4)

- 8.5 Will photoelectrons be emitted from the surface of this metal if it is irradiated with X-rays? Give a reason for the answer.

(2)

[13]

QUESTION 9

Given the circuit below , the battery reading is 12V and the resistors in parallel are 2Ω and 6Ω respectively. The resistor in series is equal to 1Ω .

- 9.1 Define Ohm's Law in words.

(3)

The switch is **open**. Determine

- 9.2 the reading on V_1 .

(1)

The switch is **closed**. The voltmeter reading drops to $11,5\text{V}$. Determine :

- 9.3 the reading on V_1 .

(1)

- 9.4 the total resistance of the circuit. (4)
- 9.5 the ammeter reading **A** . (4)
- 9.6 the reading on voltmeter V_3 . (3)
- 9.7 the reading on ammeter A_1 . (4)
- 9.8 the internal resistance. (3)

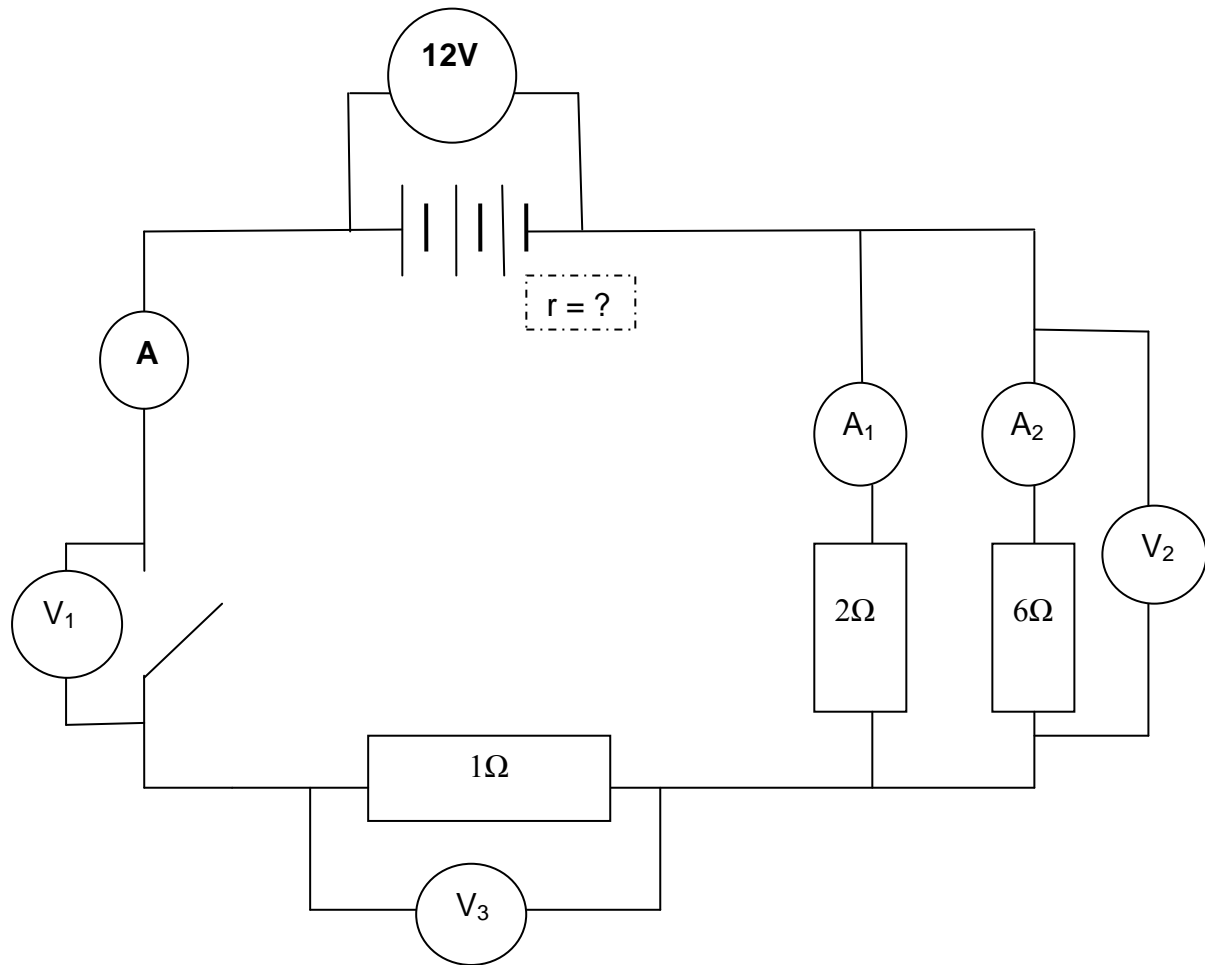

QUESTION 5

Two mass pieces, 5 kg and 7 kg respectively, are connected by an ideal string. The string is passed over a pulley and the mass pieces hang down on either side of the pulley. Initially, they are held stationary, both exactly 1,5 m from the pulley.

They are released simultaneously. Redraw the sketch and mark off your tension in the string.

Determine :

5.1 the acceleration of the system . (6)

5.2 the tension in the string (4)

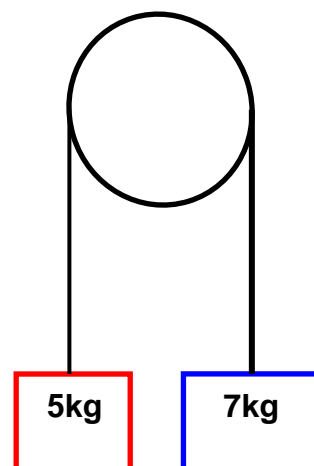

[10]

QUESTION 11

Given the circuit below , the battery reading is 12V and the resistors in parallel are 2Ω and 6Ω respectively. The resistor in series is equal to 1Ω .

11.1 Define Ohm's Law in words. (3)

The switch is **open**. Determine

11.2 the reading on V_1 . (1)

The switch is **closed**. The voltmeter reading drops to 11,5V . Determine :

11.3 the total resistance of the circuit. (4)

11.4 the ammeter reading **A** . (4)

11.5 the reading on voltmeter V_3 . (3)

11.6 the reading on ammeter A_1 . (4)

11.7 the internal resistance. (3)

